



PROLITEC

PERFECTLY SCENTED ENVIRONMENTS

AQ160



AIRQ
BY PROLITEC

Original Instructions

Rev. 2018-04-18

AQ160 User Guide

Table of Contents

1. Welcome to Prolitec

Applications & Uses

2. IMPORTANT SAFETY INSTRUCTIONS

3. Controls and Display

4. Setting Up AQ160

Equipment and Accessories

Getting Started

Removing the Cover

Connecting to Power

Inserting the Cartridge

Setting the Clock

Selecting Operating Mode

24/7 Mode Setup

Program Mode Setup

Replacing the Cover and Inserting the Director Attachment

Setting the Scent Control

Room Size Chart

Room Placement Considerations

Adjusting the Scent Level

Scent Cycles

5. Troubleshooting

6. Frequently Asked Questions

7. Care and Maintenance

8. Specifications

9. Warranty

Welcome to Prolitec

You have purchased the AQ160 – the table, floor, or shelf positioned model of the most advanced commercial scenting technology available anywhere. The AQ160 is engineered to provide a significantly better scent effect than traditional devices. The AQ160 offers the following features – important for commercial applications and not available from others:

- **Adjustable 1 to 50** – just the right intensity for spaces 100 to 1,900 square feet (3 to 54 square meters).
- **Programmable** – up to three schedules per day allows for scenting only when the space is occupied.
- **Consistent scent character** – the scent smells exactly the same on day 60 as it did on day 1.
- **Uniform coverage** – the scent is even everywhere – no strong or weak spots.
- **Long life cartridge** – 5 to 110 days depending on intensity and extendable by using a schedule.
- **Safe** – scent effect complies with all workplace safety guidelines and rules including OSHA and State of California.
- **Hypoallergenic** – patented process produces scent with only a trace concentration of scent molecules minimizing chance of allergies.
- **Clean** – produces no soot and leaves no residue on surfaces

This User Guide contains valuable tips and simple instructions. We urge you to read it carefully and completely.

Applications and Uses:

There are four basic applications for the AQ160:

1. Ambient Scenting

Ambient Scenting is the use of a scent to improve the customer experience; enhance the environment; create a mood or ambience. Prolitec offers a variety of choices in scents to help you achieve this. For example, a retail shop might use pleasant scent to cause customers to linger longer.

2. Odor Control

Odor Control is the use of Prolitec's proprietary odor control technology to erase bad odors and replace them with an appealing scent effect. A bad odor creates a negative impression, and erasing it is a high priority for any space occupied by customers. For example, a perfectly clean store might have an unattractive smell because of the packaging on product or a nearby food preparation area AQ160 can deal with virtually all odors.

3. Scent Marketing

This is the use of scent to sell a product. For example, the smell of fine fragrance in the air encourages customers to try the fragrance. The smell of a natural coffee in the air encourages attendance at the food counter. The smell of chocolate stimulates interest in candy.

4. Aromatherapy

The use of scent to achieve some cognitive outcome is called Aromatherapy. Certain scents relax or invigorate, and certain scents have been found to help improve mood, efficiency, and attention.

IMPORTANT SAFETY INSTRUCTIONS – SAVE THESE INSTRUCTIONS

INSTRUCTIONS PERTAINING TO A RISK OF FIRE, ELECTRIC SHOCK, OR INJURY TO PERSONS

- The device is built to be plugged into an 100-240VAC power outlet.
- AQ160 must be used only with the approved and included power supply.
- The UL and CE compliant power supply converts power to 15V DC to power the device.
- The device must only be supplied at Safety Extra Low Voltage (SELV).
- If the supply cord is damaged, it must be replaced by the manufacturer, its service agent, or similarly qualified persons in order to avoid a hazard.

Device Precautions:

WARNING – When using electric products, basic precautions should always be followed, including the following:

- Read all the instructions before using the product.
- Do not put fingers or hands into the product.
- The device must be operated in an upright or vertical position.
- Never put your nose to the output of AQ160. Within 12 inches (30 cm) of the output, the fragrance is highly concentrated. The improper inhalation of high concentrations of fragrance may cause irritation including watery eyes, headache, cough and upper respiratory discomfort.
- Unplug before cleaning or moving.
- It is recommended that the user periodically remove the device from the wall to test and reset the GFCI (ground fault circuit interrupter) breaker in the center of wall outlet plate.
- Must be used only with the supplied and approved Power Supply.
- Unit will not operate properly if positioned sideways or upside down. AQ160 must not be tilted or turned upside down when fragrance cartridge is inside. Tilting the AQ160 will cause the fragrance to spill.
- DO NOT position AQ160 so that the output is directed at a surface closer than 12 inches (30cm). Use the Director attachment to help avoid this.
- Do not immerse in or place near water, sink or bathtub.
- This appliance is not intended for use by persons (including children) with reduced physical, sensory or mental capabilities, or lack of experience and knowledge, unless they have been given supervision or instruction concerning use of the appliance by a person responsible for their safety.
- Children should be supervised to ensure that they do not play with the appliance.

Cartridge Precautions

READ THE SAFETY INFORMATION SHEET ENCLOSED WITH EACH CARTRIDGE.

- Wash your hands after all contact with cartridges or fragrance. The concentrated nature of the fragrances may make the scent difficult to remove from hands and skin.
- If there is contact with the eyes, irrigate the eye with fresh water for five minutes. If there is any eye irritation, consult a physician immediately.
- **IMPORTANT:** Always keep plugs in cartridges when not in use. If you have misplaced the plugs from the cartridge being removed, you can use the plugs from the new cartridge being inserted.
- **SPILLS: KEEP THE LID ON TO AVOID DRIPS AND SPILLS** on furniture, carpets and fabrics. If there is a drip or spill, blot immediately with a damp cloth and then wash with soap and water. For carpets and fabric, blot up a small spill or place dry towels on a larger spill. Allow the towels to absorb as much liquid as possible. Switch damp towels for dry towels until no more liquid can be absorbed from the spill. Cover the remaining portion of the spill with baking soda and allow it to set for three minutes before vacuuming. Repeat this process up to two more times if needed. If the smell of perfume persists, professional cleaning may be required. Spills on wood or other porous and painted surfaces must be cleaned immediately with soap and water to avoid severe damage.
- While Prolitec formulations do not contain ingredients deemed harmful to the skin, if there is skin contact, wash with soap and water. If there is contact with the eyes, irrigate the eye with fresh water for five minutes. If there is any eye irritation, consult a physician immediately
- Take care to **NOT** drop a cartridge. It may crack, causing fragrance to spill. Call Prolitec Product Safety and Support toll-free at **1-844-247-7599**.

Controls and Display

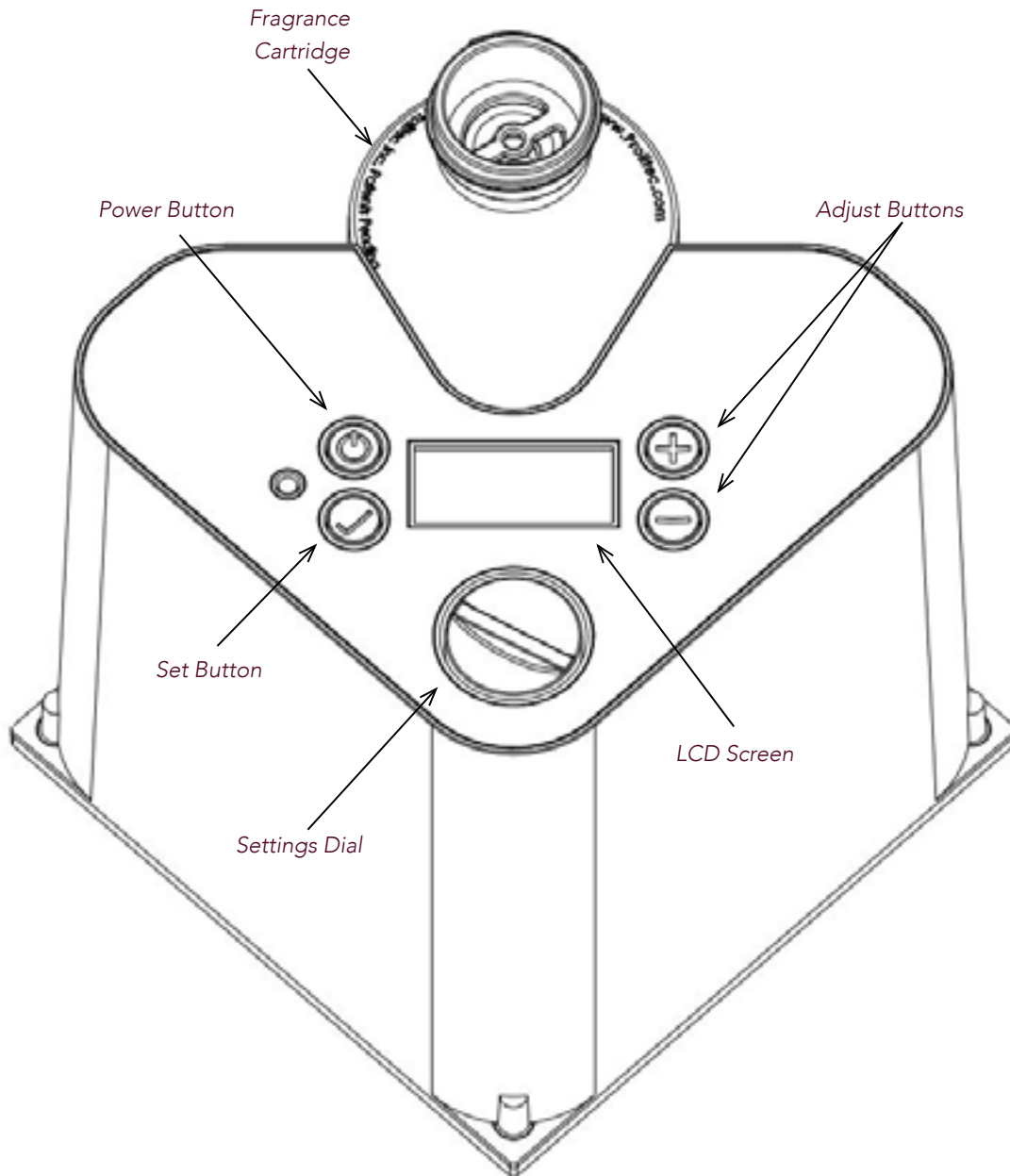

Setting Up the AQ160

Equipment and Accessories

Remove AQ160 from the container. Included:

1. Appliance
2. Power Supply (includes world-plug assortment, not shown)
3. Director Attachment
4. Fragrance Cartridge (sold separately)

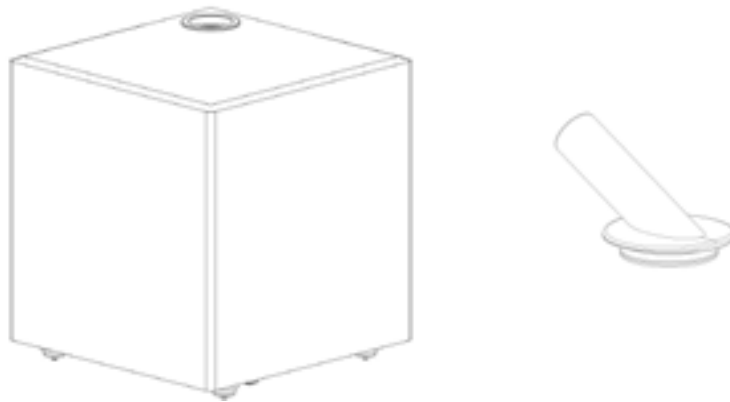

Getting Started

Removing the Cover

The cover of the cube is removable as shown below.

To remove cover, locate release tab at bottom of the unit, press in, and lift cover up and off with other hand.

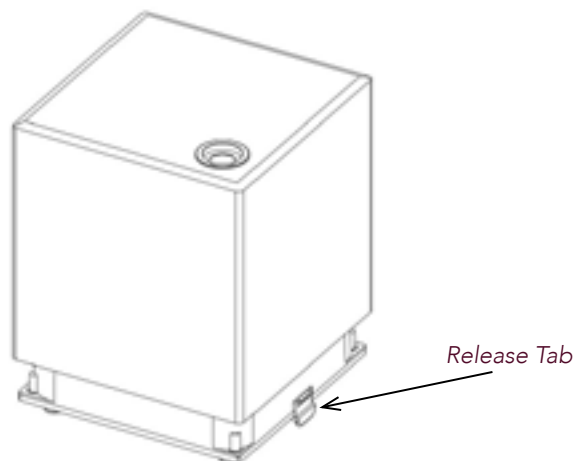

Connecting to Power

1. Connect the power cord to the underside of the appliance.
2. Attach appropriate, country-specific plug to power block.
3. Plug the power block into an AC outlet within reach of the location you have chosen.

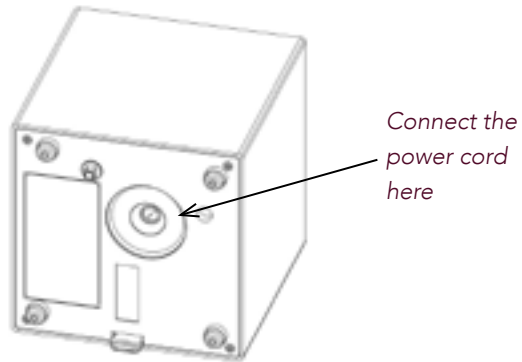

Inserting the Cartridge

1. Remove screw-top cap, bottom plug (save for future storage) and foil seal.
2. Insert cartridge, pressing firmly until cartridge sits in place. (Fig. 1)

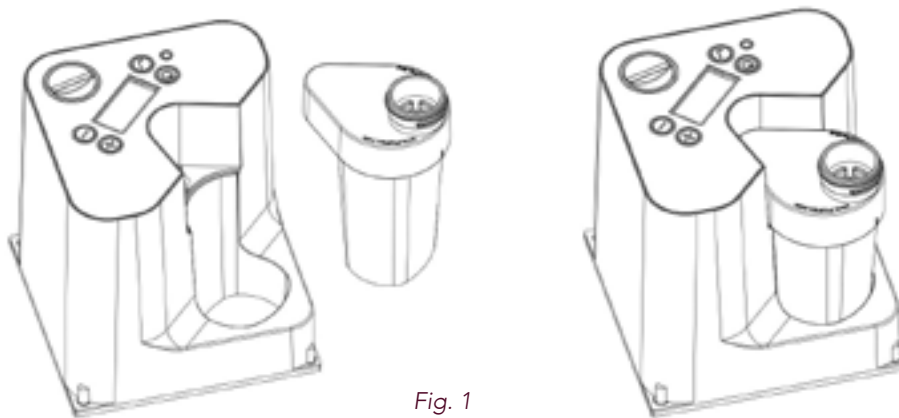
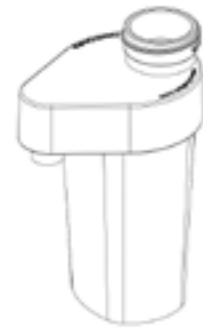

Setting the Clock

1. Turn the dial to Set Clock.
2. Adjust using the +/- buttons.

Selecting Operating Mode

With the cover off, decide which mode of operation you want to use.

1. 24/7 mode allows for continuous scenting at the intensity level you select. It requires you to turn AQ160 ON and OFF to interrupt scenting.
2. Program mode allows you to set three programs of start/stop times to run every day, weekdays only, weekend days only, or to run only on individual days of the week.

24/7 Mode Setup:

1. Turn the dial to Run 24/7.
2. Set desired intensity level (1-50) for 24/7 operation by pressing the +/- buttons.
3. Place the cover back on the appliance.

Program Mode Setup:

1. Turn the dial to Set Program. The Program icon comes on above the time.
2. The "Sun" (Sunday) icon will blink, indicating you are setting a program for Sunday only. Use the +/- buttons to scroll to the day or days you want the program to run. After selecting the day, press the Set button to advance to programming options.
3. Now the "1" icon is turned on to indicate you are setting program 1. The Rate (intensity) digits blink to prompt you to set the rate. You may set to any value between 1 and 50, or set to 00 to disable the program. Press the Set button to advance to programming Start and End times.

NOTE: If you set the rate to 0, then the current and subsequent programs are all disabled. For example, if the rate for program 2 is 0, then program 2 and 3 are disabled.

4. If you set a non-zero rate, then the Rate digit changes to "S" to indicate **start** time. The hour digit should blink to prompt you to set the start hour. Use the +/- buttons to set the hour (make note of AM or PM). Then press the Set button to advance and set the minute. Press the Set button to advance to program the end time.
5. The rate digit now changes to "E" to indicate you are setting the **end** time. Use the +/- buttons to set the end time. Press the Set button to advance to the next program.
6. Program icon 2 should now turn on. Use the +/- and Set buttons to set the start and end times for program 2 (if needed) and then for program 3 (if needed). Note that if you need only 1 or 2 programs for the day, you simply disable the subsequent programs by setting their rates to 0.

7. After setting the programs, turn the dial to Run Program and your AQ160 will be ready to go.

IMPORTANT: For scent level settings 1-49, AQ160 will stop releasing fragrance for a period of two minutes between scenting cycles. Scent cycles will vary in length based on intensity settings. This is normal and does not mean the machine is malfunctioning. Setting 50 is always on and has no off cycle.

Replacing the Cover and Inserting the Director Attachment

1. Replace cover, pressing down until the reassuring click is felt and heard.
2. Insert the Director Attachment and adjust to direct the AQ160 output away from any nearby surfaces less than 12 inches away. (See "Room Placement Considerations") Use of the Director Attachment also dampens the normal noise from the output.

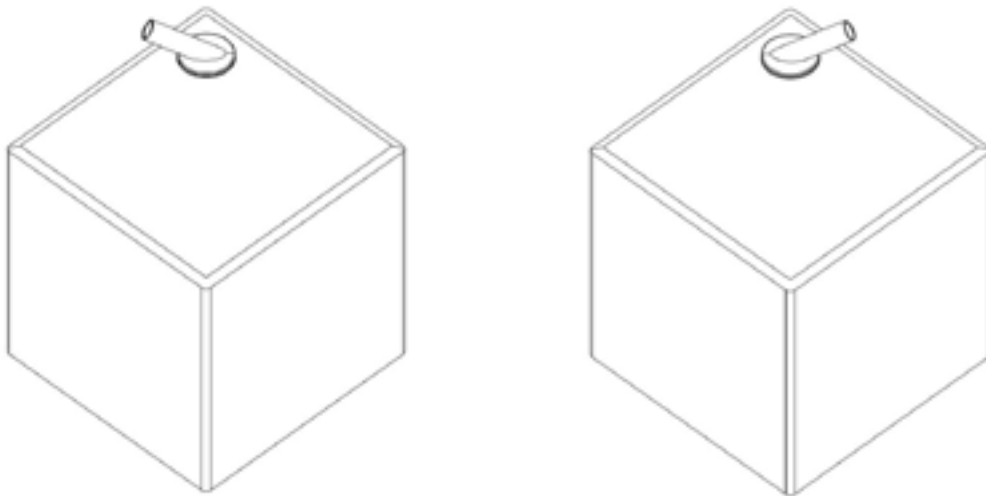

Setting the Scent Control

This feature allows you to select the appropriate amount of scent for the room size. It is important to start at a low setting to avoid too strong of a scent level. If needed, you can gradually increase the scent level until it is just right for you. Remember; always allow 15 minutes between changes in scent level before adjusting again. (See "Adjusting the Scent Level")

1. Determine the approximate size of the room you wish to scent by consulting the Room Size Chart as shown.

Room-Size Chart

Intensity Setting	Room Area Range in FT ²	Room Area Range in m ²
1 thru 5	100 - 300	3 - 8
6 thru 10	400 - 600	11 - 17
11 thru 15	600 - 800	10 - 23
16 thru 20	900 - 1000	25 - 28
21 thru 25	1100 - 1200	31 - 34
26 thru 30	1300 - 1400	37 - 40
31 thru 35	1400 - 1500	40 - 42
36 thru 40	1600 - 1700	45 - 48
41 thru 45	1700 - 1800	48 - 51
46 thru 50	1800 - 1900	51 - 54

2. Using the +/- buttons just to the right of the LCD, set the scent level indicated by the Room Size Chart.

Room Placement Considerations

Place AQ160 in a desired location that cannot be easily accessed by young children or pets. The top of a shelf or cabinet is a good location.

Use the Director Attachment to direct the AQ160 output away from any nearby surfaces less than 12 inches away.

Do not place AQ160 near an open window if the air is blowing out, as the scent will be less detectable in the space. Be mindful of airflow in the area to be scented and position AQ160 so that the natural air currents do not stop the flow of AQ160 scent into the space. Lighting a match,

blowing it out and then watching the flow direction of the smoke can be helpful in determining this.

Exercise care while changing cartridges when AQ160 is placed on furniture or surfaces that may be harmed by contact with the liquid fragrance.

Adjusting the Scent Level

Take the time to get the scent level just right. If you followed the Room Size Chart, you have set AQ160 to the low end of the range for your room size. If after at least 15 minutes the scent is not detectable, increase the setting by one or two levels at a time. Keep increasing until you and others can just detect the scent when you enter the space. It is best to leave the room each time the scent level is adjusted and allow about 15 minutes for your nose and the scent level to adjust.

Scent Cycles

The AQ160 scent-intensity levels are designed through the use of on and off duty cycles. A higher scent intensity setting will cause the unit to cycle on for longer periods of time. A lower scent intensity setting will cause the unit to cycle on for a shorter period of time. For all settings except 50, there will be a cycle off period.

Troubleshooting

The scent in the room is too strong or too weak.

If the scent is too weak, first make sure that AQ160 is not positioned near an open window or door so that all its scent is blowing out of the room. Reposition AQ160 as far away as possible from open windows or doors.

Adjust Fragrance Release Rate using the +/- buttons. In general, adjustments should be made in small increments. Especially with settings less than 10, move up or down by one level at a time. Whenever changing a setting, allow at least 15 minutes to rebalance before checking the scent level again.

If you cannot detect the scent, check to make sure the cartridge is not empty.

The appliance is not turning ON.

Make sure the power cord is properly plugged in to both the AQ160 and the electrical outlet (plugged in at both ends).

Make sure the Dial is set to 24/7 or you have programmed AQ160 for automatic operation and set the Dial to Program.

Make sure the cover is firmly in place.

Make sure the appliance is placed on a flat surface. There is a safety switch on the bottom of the AQ160 that disengages the pump should AQ160 be tipped over or not on a level flat surface.

Press the **POWER** button to illuminate the blue light. Once the cover is replaced over the AQ160, the appliance should turn on.

If you cannot detect the slight vibration when touching the appliance, call customer support toll-free at 1-844-247-7599.

With AQ160 operating in a bookshelf, the output is directed straight up to the next shelf.

Insert the Director Attachment provided with AQ160 to direct the output forward and away from the bookshelf.

AQ160 makes too much noise.

AQ160 is designed to a very low noise specification. Inserting the Director Attachment should reduce any AQ160 noise even further. If the problem persists, make sure the cartridge is firmly in place by removing it and putting it back in, sliding down until a firm click is felt. If the problem persists, call customer support toll-free at 1-844-247-7599 or go to www.prolitec.com.

Frequently Asked Questions

How does AQ160 work?

AQ160 uses a recently patented technology to convert liquid fragrance compounds into tiny droplets less than 1/50th the diameter of a human hair. By comparison, an aerosol droplet is 100 times bigger and 1,000,000 times heavier. AQ160 droplets present 100 times more surface area to the air they are treating, which means much less fragrance is used to create the scent effect. AQ160 tiny droplets are extremely light, so they float easily into the air and disperse throughout a space to create a consistent scent effect.

Where can I place AQ160™?

Do you want to conceal it or display it? You can place AQ160 just about anywhere in a room that is not within reach of young children or pets and where power can be accessed with the power cord provided. You can place it in a bookshelf, hidden on the floor behind a chair, sofa or floor lamp — anywhere there is some space for air to circulate and where AQ160's output is pointed away from surfaces less than 12 inches away. Avoid placing AQ160 near a window that is sometimes opened.

Do I need to adjust AQ160?

Yes! AQ160 is a powerful machine. The scent control setting is very important. AQ160 can handle very small and very large rooms. If set too high for room size, it can cause discomfort for some people. Adjusting is simple. Take the time to do it right.

How do I adjust AQ160 ?

With the cover removed, you can adjust AQ160 up and down using the +/- buttons just to the right of the LCD screen. You can see the setting level (1 to 50) on the right side of the LCD. ALWAYS START WITH THE RECOMMENDED SETTING and adjust upward in small steps.

How strong should I make the scent?

Less is more. AQ160 allows you to erase odors and use only a small amount of scent. Unlike all other air fresheners, AQ160 is adjustable. Use this important feature. Always start on the lowest settings for the size of the space, then adjust upward in small steps.

I hear the unit running, but there is no scent or plume.

1. Ensure power switch is off before inserting cartridge.
2. Cartridge: remove caps (save for future storage) and foil seal. Insert cartridge, pressing firmly until cartridge sits in place.
3. To activate cartridge: using a tissue or paper towel, press in the stem in the center of the top output chimney; the stem should spring back.

My AQ160 does not run for several minutes at a time. Is this normal?

The AQ160 scent intensity levels are designed through the use of on and off duty cycles. Therefore, a higher scent intensity setting will cause the unit to cycle on for longer periods of time. A lower scent intensity setting will cause the unit to cycle on for a shorter period of time. For settings 1–49, there will be a two-minute off cycle in between periods of operation.

IMPORTANT

ALWAYS ALLOW AT LEAST 15 MINUTES TO ASSESS the scent strength after starting or adjusting. It is best to assess strength when you first enter the room from another room.

Odors, can AQ160 help with these?

YES! Most odors can be completely erased by AQ160. Each fragrance contains a patented component specifically aimed at odors. This feature allows you to eliminate odors without having to make the scent too strong. This is a major advantage over aerosols and plug-ins that must douse an odor with too much fragrance.

How about safety? Is AQ160 safe to use around children?

Used as directed, AQ160 is the safest air freshener available. Of course, it is important to read the Consumer Safety Information Sheet enclosed with each cartridge. Store cartridges out of the reach of young children.

I have always used candles to create a scent. How is AQ160 different?

AQ160 safely creates a beautiful non-waxy scent and is adjustable to serve a much larger space than a candle. An open flame requires supervision and produces black soot that can be inhaled and leaves deposits on surfaces. AQ160 leaves no deposits.

How does AQ160 differ from aerosol room fresheners?

The more expensive aerosols can produce a very pleasant scent, but only for a few minutes, and in very high concentrations just in the area sprayed. AQ160 is what is known as a “continuous action” air freshener. AQ160 is always on and delivers an evenly distributed scent throughout the room.

Is AQ160 eco-friendly?

YES! AQ160 is the most eco-friendly air freshener on the market. Unlike candles, AQ160 produces no black soot or residual hydrocarbons. Unlike aerosols, AQ160 uses no propellants and produces no harmful volatile organic compounds or VOCs. Unlike many air fresheners, AQ160 uses no ethanol or similar solvents to enhance the evaporation of fragrance chemicals.

I only want to scent the room at certain times. Do I have to turn it on and off every time?

AQ160 has a tiny on-board computer for fully automatic operations. You can set the time to start and the time to stop each day. See “Programming.”

How long does a cartridge last?

Operating for 24 hours a day at a high setting, a cartridge will last several days. At lower levels and operating for fewer hours per day, the cartridge will last proportionately longer. Also note that different fragrances consume at different rates.

Why does a new cartridge arrive looking “less than full?”

Space is required in the cartridge for AQ160 to properly nebulize the liquid inside.

If I want a different scent, can I switch cartridges?

Yes, simply remove the cartridge and replace it with another. When not in use, remember to replace the cap on the cartridge openings so the fragrance doesn't drip, evaporate or change while out of the AQ160. Store upright in a cool, dry space and take care to wipe off any liquid on the outside of the cartridge before storage.

Will AQ160 leave deposits on furniture or carpeting?

AQ160 will not leave deposits provided you do not direct the output at a surface closer than 12 inches. You should use the Director Attachment to direct the output away when you place AQ160 underneath something, such as in a bookshelf.

IMPORTANT

Always keep the caps on cartridges that are stored outside of the AQ160. If you have misplaced the caps from the cartridge being removed from AQ160, you can use the caps from the new cartridge being inserted.

What happens if AQ160 is knocked over? Will it continue to function?

Should AQ160 be tipped or knocked over to a position other than upright and level, a sensor switch on the bottom of the appliance prevents AQ160 from functioning until the unit is placed back into its correct, upright position. It is important to note that while the cartridges are designed to be leak-proof, a small amount of fragrance could spill from the appliance and cause damage if the appliance is knocked over.

It is important to wipe or blot up any spill as quickly as possible.

I'd like to take AQ160 with me when I travel, to scent another space. Are there any precautions?

1. The AQ160 was designed to be small enough for travel and there are some precautions to take when doing so:
2. Always remove the cartridge from the appliance taking care to re-cap, re- plug and place in a sealed zip-top bag for travel. As the induction, or foil seal has been removed for its initial use, there may be slight leakage from the cartridge cap due to change in air pressure when traveling by plane. Placing the cartridge in a zip-top bag is strongly recommended to avoid leakage on the contents in the luggage.
3. Consult current TSA restrictions for carry on liquids for planes. It is likely the AQ160 cartridge will need to be checked in your luggage and not allowed in your carry on items.
4. Upon arrival at your destination, take care to "re-activate" your cartridge as shown in the set-up guide on page 10 before turning the AQ160 on.

Will AQ160 fragrances stain surfaces or fabric if there is a spill?

Yes, all air care fragrances will stain wood, stone and all fabrics. The best solution is avoidance by replacing the caps on cartridges after removing them and keeping the caps on all cartridges when not in use.

How do I clean up a drip?

If there is a drip, blot it as quickly as possible and then clean with soap and water. See page 6, "AQ160 Cartridge Precautions," for more detail.

Care and Maintenance

Care:

- AQ160 is an electronic appliance with a built-in computer.
- AQ160 must not be tilted or turned upside down when fragrance cartridge is inside. Otherwise there will be a spill.
- Do not place or store AQ160 or its cartridges in extreme heat (more than 130°F/54°C) or in freezing temperatures.
- Do not drop AQ160 on the floor. Do not drop it in or position it near water.
- Do not paint or otherwise try to alter the color of the outer cover.
- When shipping, pack in the original box, then place in an outer cardboard box.
- Always keep the lids on cartridges when stored outside of the AQ160 .
- Caution: do not position directly under lights or other heat sources up to and over 100 degrees. Damage to the housing may occur.

Routine Maintenance:

- When you change a cartridge, wipe off the inside and outside surfaces with a damp cloth that contains a small amount of a detergent-based cleaner. Then wipe again with a clean, damp cloth. Unplug the AQ160 before cleaning it.
- When wiping down, do not plug up the air intake or output with cloth or other particles.

Specifications

Dimensions: AQ160 Appliance 5.3" x 5.3" x 6" (13.5 cm x 13.5 cm x 15.2 cm)

Weight: 2.6 lbs. (1.2 kg)

Power Supply: Rated input: 100 – 240 VAC, 50 – 60Hz 0.6 max

Rated output: 15VDC 400 – 1200mA

Approvals: FCC Part 15, CE & RoHS Compliant

Working Temperature: 32° F to 104° F (0° C to 40° C)

Working Humidity: 85% or less

Liquid Capacity: 105mL Prolitec cartridges

Performance: Up to 10,000 feet³ (283 m³)

Warranty

What Is Covered

This warranty covers any defect in materials or workmanship, with the exceptions stated below.

How Long Coverage Lasts

This warranty runs for one (1) year from the date of the original purchase.

What Is Not Covered

This warranty does not cover damage caused by misuse or use other than as intended and described in the product instruction manual, or loss or damage to batteries or removable parts.

What Prolitec, Inc. Will Do

Prolitec Inc. warrants this product against defects in materials and workmanship. When repair is not practical, Prolitec Inc. will have the option to replace the defective product with a fully warranted, factory-reconditioned product that is the same or has similar functionality.

How to Obtain Service

For Prolitec Product Safety and Support, call toll-free at 1-844-247-7599.

This warranty gives you specific legal rights, and you may have other legal rights that vary from state to state.

© 2017 Prolitec Inc. 1235 W. Canal Street Milwaukee, WI 53233